



OMEGA

Curved Inclined Platform Lift

PLANNING GUIDE

Applicable Codes:

ASME A17.1

ASME A18.1

CAN/CSA B355

CAN/CSA B613

Copyright © 2012
Savaria Corporation
All rights reserved.

Printed in Canada

Purpose of This Guide

This guide assists architects, contractors, and lift professionals to incorporate the OMEGA Inclined Platform Lift into a residential or public building design.

The design and manufacture of the OMEGA Inclined Platform Lift meets the requirements of the following codes and standards:

- ASME A18.1-2003 Section 3 (Public)
- ASME A18.1-2005 Section 3 (Public)
- ASME A18.1-2008 Section 3 (Public)
- ASME A18.1-2003 Sections 5 and 6 (Private)
- ASME A18.1-2005 Sections 5 and 6 (Private)
- ASME A18.1-2008 Sections 5 and 6 (Private)
- ASME A17.1-2000 Section 20
- ASME A17.1-2000 Section 21
- CAN/CSA B355 S1-02 (Public)
- CAN/CSA-B355-09 (Public)
- CAN/CSA B613-2000 (Private)

We recommend that you contact your local authority having jurisdiction to ensure that you adhere to all local rules and regulations pertaining to inclined platform lifts.

IMPORTANT: This Planning Guide provides nominal dimensions and specifications useful for the initial planning of an inclined platform lift project. **Dimensions and specifications are subject to change without notice due to continually evolving code and product applications.**

Before beginning actual construction, please consult Savaria Corporation or the authorized Savaria dealer in your area to ensure you receive your site-specific installation drawings with the dimensions and specifications for your project.

Visit our website for the most recent drawings and dimensions.

How to Use This Guide

- 1 Determine your client's intended use of the lift.
- 2 Determine the local code requirements.
- 3 Determine the site installation parameters.
- 4 Plan for electrical requirements.

History

February 6, 2012 – Initial release

February 14, 2012 – Corrected codes above

Contents

Description of the lift	5
Features and benefits	5
Specifications of the lift	6
Lift components	7
Standard drive unit with remote controller box (top landing)	8
Optional drive/controller cabinet (top landing)	8
Overspeed governor (bottom landing)	8
Lift controls	9
Guide rails	10
Guide rail mounting	11
How the system works	12
Safety features	13
Obstruction sensors	13
Safety arms and platform ramps	13
Safety brake (overspeed governor)	13
Limit switches	13
Emergency stop button	13
Audio visual alarm.....	13
On-board alarm button	13
Platform key switch	13
Overspeed governor	13
Manual lowering device	13
Site verification	14
Stairway	14
Minimum overhead clearance	14
Construction site	14
Dimensions	14
Installation	14
Electrical requirements	15
General	15
Main power supply	15
Lighting	15
Structural requirements	16
Floor/support wall loads	16
Support load diagram	16
Unfolded platform dimensions	17
Folded platform dimensions	18
Lower level clearances	19
Turning clearances (90 degree curve)	20
Turning clearances (180 degree curve)	21
Standard drive unit clearances	22
Remote controller box dimensions	23
Optional large drive/controller cabinet dimensions (sheet 1)	24
Optional large drive/controller cabinet dimensions (sheet 2)	25
Call station dimensions	26
Sample installation wiring layout	27

Description of the lift

The OMEGA Inclined Platform Lift is an accessibility device used to provide access over multiple levels of straight stairs, stairs with intermediate landings, or stairs with turns.

The lift will transport a passenger either sitting in a wheelchair or on the folding seat.

The unit travels along the guide rails at a comfortable speed up to 14 feet per minute (0.07 metres per second).

The unit is driven by a rope traction drive system. The standard drive unit is mounted on the rail at the top of the stairs (for rail lengths under 20 metres) or in an optional drive cabinet (for rail lengths over 20 metres).

The OMEGA is easy to operate using the on-board pendant control. When the lift is not in use, it can be parked and folded up allowing access to the stairs.

The OMEGA is suitable for either indoor or outdoor use, and can be factory-built for left- or right-side rail installations.

Features and benefits

- Major building renovations are usually not required as the OMEGA is installed on a modular guide rail system that follows along an existing stairway. The rails will be securely fastened to a supporting wall, the stairs, or both.
- The space-saving design of the platform and the rail system allows the platform to fit into narrow staircases.
- The lift can be parked at the top or bottom of the staircase.
- A tight turning radius is possible.
- Inside or outside curve installations are accommodated.
- The lift platform is ADA-compliant.
- A compact standard drive is installed at the top of the rail system. An optional larger drive cabinet can be used for longer runs (over 20 metres).
- The rope traction drive system allows for longer installation runs.
- A robust platform motor operates folding and unfolding of the platform, arms and ramps.

Specifications of the lift

Specification	Data
Maximum load	550 lb (250 kg)
Gradient	Variable up to 55°
Capacity	One person in wheelchair or sitting on the folding seat; seat capacity is 330 lb (150 kg)
Platform sizes	49.2" x 30.5" (1250 mm x 775 mm) 35.4" x 28.3" (900 mm x 720 mm)
Travel speed	14 feet/minute (0.07 metres/second)
Maximum travel	164 ft (50 m)
Travel direction	Forward/backward
Temperature	+113 °F to -31°F (+45 °C to -35°C)
Humidity	Maximum 70% Not for use in bathrooms or swimming pool areas
Noise	Less than 70 db
Power supply	240 VAC
Motor	1 hp (0.75 kW), 2.2 kW over 30 m
Pendant control buttons	Two constant-pressure directional buttons to move the lift up or down the stairway and an emergency STOP button to stop the lift in an emergency
Remote call station buttons	Used to call/send the lift and fold/unfold the platform (if automatic)
Platform control panel	Emergency STOP button to bring the lift to an immediate stop Audible alarm button to signal for help Running light to indicate the unit is in use Key switch to enable use of the pendant control buttons
Standard features	Pendant control buttons (on platform) Constant-pressure type buttons Manual lowering capability (using handwheel) Safety arms Manual folding platform (fold/unfold platform by hand) Limit switches No machine room required Emergency stop button Audio visual alarm (running buzzer and light) to indicate the unit is in use Folding seat (with seat belt)
Safety features	Edge sensors Underpan sensors Safety brake Safety arms Platform ramps Emergency stop button Limit switches Manual operation (using handwheel)
Options	Outdoor package (requires outdoor rail) Key switch for call station

Lift components

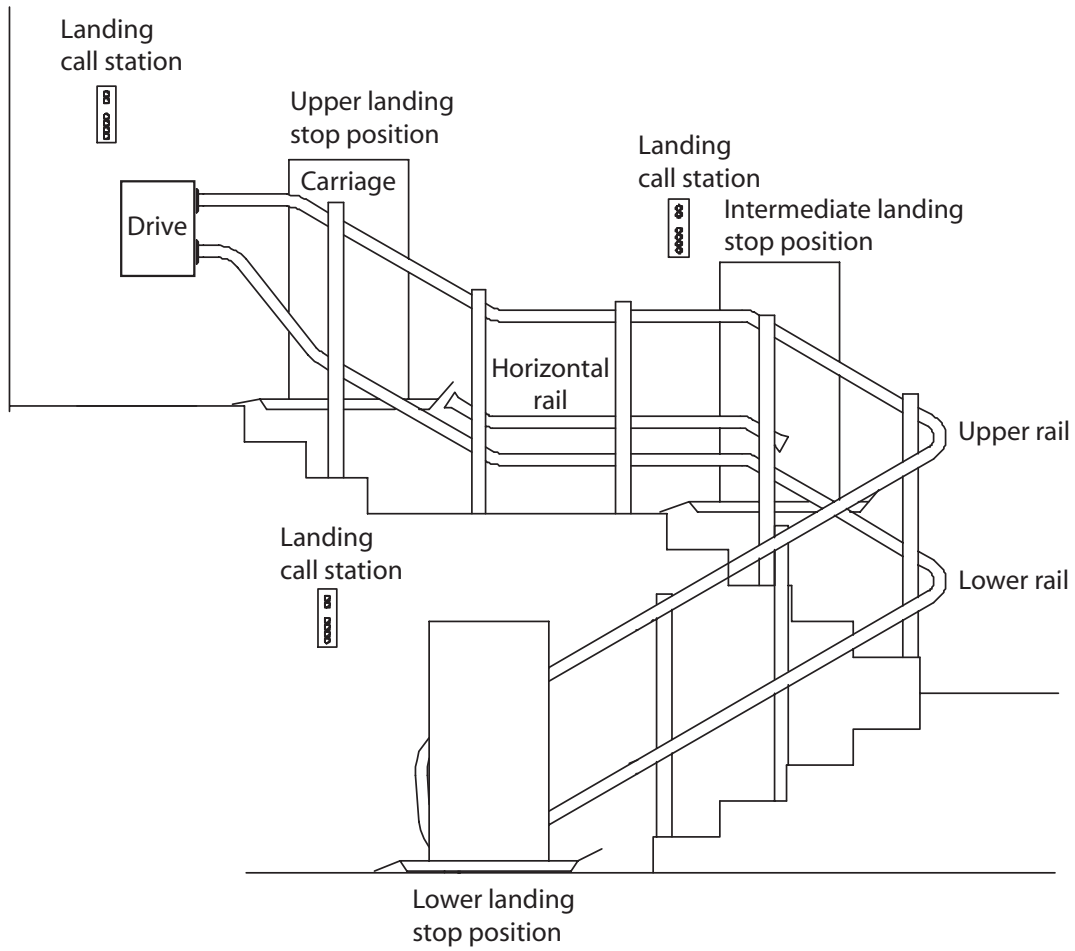

Standard drive unit with remote controller box (top landing)



Optional drive/controller cabinet (top landing)



Overspeed governor (bottom landing)

The overspeed governor is a safety device located at the lower end of the rail. It consists of an electrical switch and a mechanical device that activate together to stop the platform from moving if it is descending down the stairs too quickly.



Lift controls



PLATFORM PENDANT

The on-board, hand-held pendant has constant-pressure **UP/DOWN** buttons allowing you to move the platform up or down the stairway. There is also a red emergency **STOP** button.

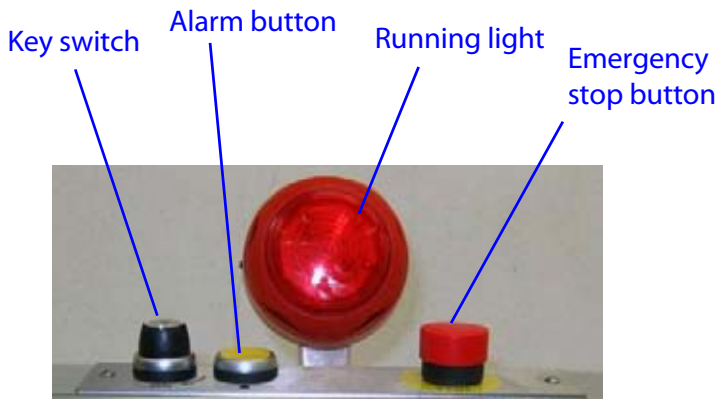

PLATFORM CONTROL PANEL

Key switch – use to activate/de-activate the platform pendant controls

Alarm button (if equipped) – use in an emergency to sound an audible alarm

Emergency STOP button – use in an emergency to stop the lift

Running light - flashes to indicate the unit is in use



CALL STATION
(for Automatic Platform)

UP

DOWN

FOLD

UNFOLD

KEY SWITCH
(OPTIONAL)

UP/DOWN buttons – use to call the lift to the required landing

FOLD/UNFOLD buttons – use to fold or unfold the platform and raise or lower the ramps

KEY SWITCH (optional) – use to activate/de-activate the call station controls

Guide rails

The lift travels up and down the stairway along two guide rails – an upper rail and a lower rail. The mounting location of the rails depends on the platform size and the angle of the stairs.

If the angle of the stairs is less than 20 degrees, a third rail (horizontal stabilizer rail) is required to stabilize the platform. Horizontal rail sections may be required at half-landings or stop positions. A sample horizontal rail installation is shown below.

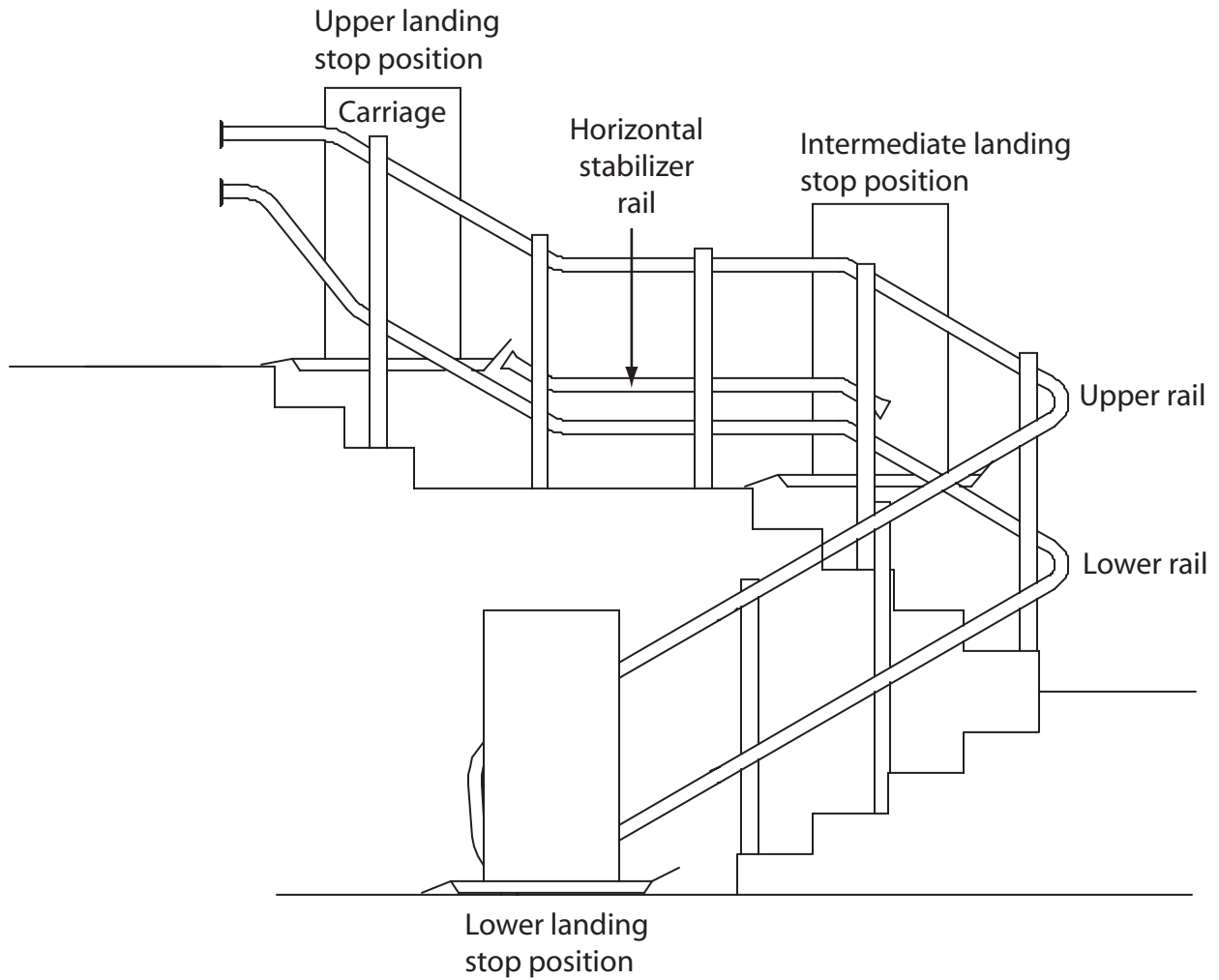

Guide rail mounting

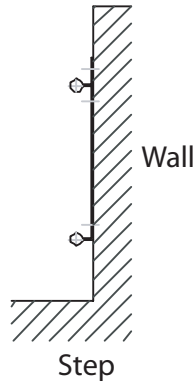

WALL MOUNTED

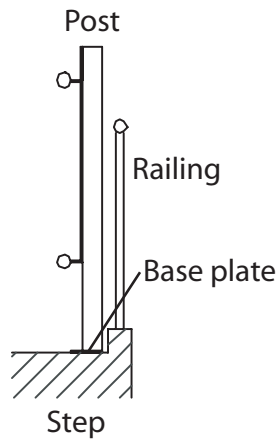

POST MOUNTED ON STEPS

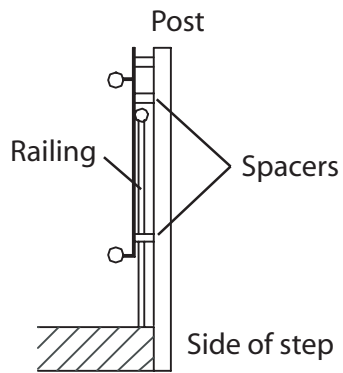

POST MOUNTED ON SIDE OF STAIRS

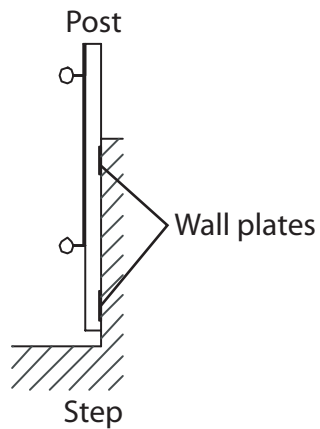

POST MOUNTED TO WALL

How the system works

The Omega carriage/platform assembly travels along a guide rail system that is custom designed for each site. This railway consists of an upper tube and a lower tube that houses a continuous loop of rope. The drive system moves the carriage/platform assembly up and down the stairs by means of this rope.

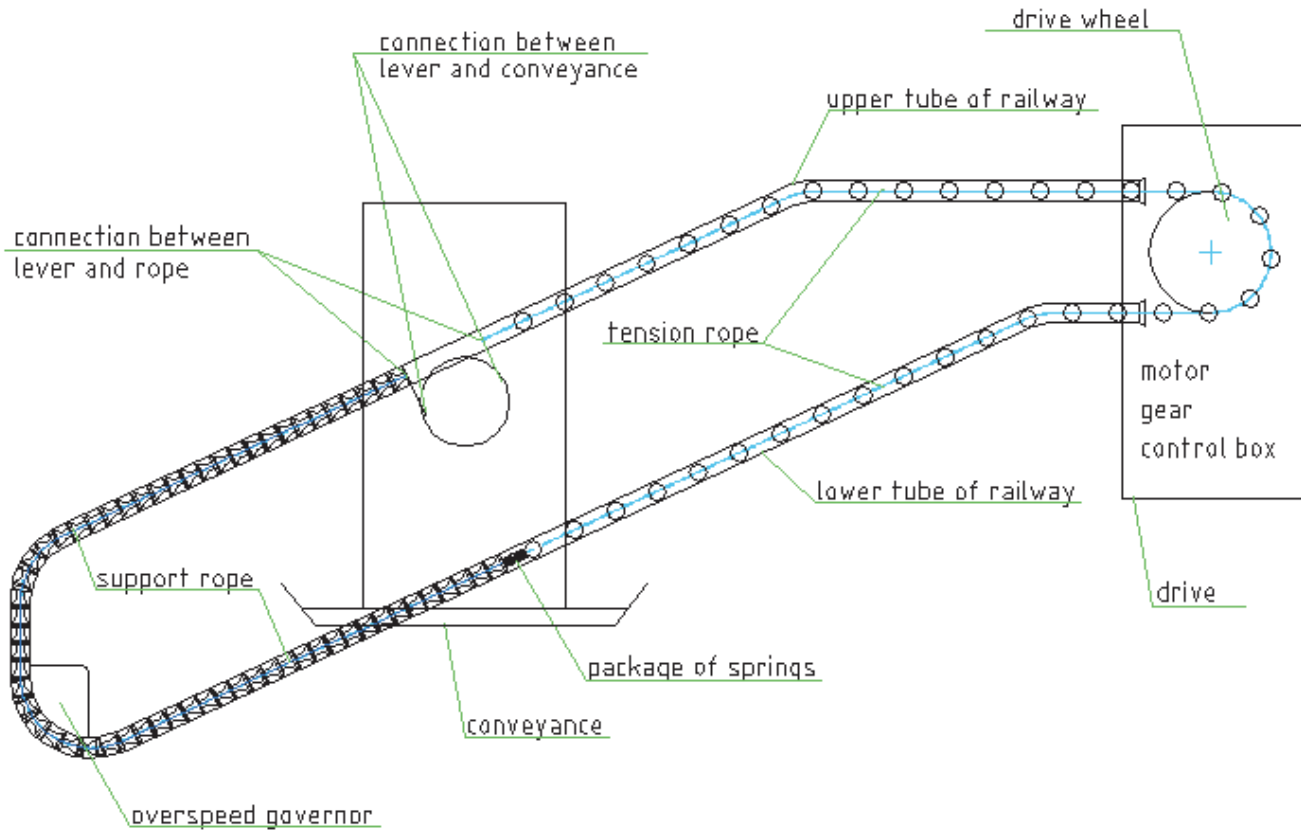

Safety features

Obstruction sensors

During travel, the edges of the platform ramp and the carriage of the lift are protected by sensors which stop the lift if it touches an obstacle.

There are also safety underpan sensors to detect an obstacle underneath the platform and carriage and stop the lift.

Safety arms and platform ramps

While in motion, the platform is protected by two safety arms. The platform is also protected by two side access ramps (and an optional front access ramp) which have the dual function of facilitating access to the lift at the floors (open position) and of retaining the wheelchair while the lift is in motion (safety position).

Before the lift leaves the floor, the safety arms must be down and the platform ramps must be up.

If the safety arms or platform ramps encounter an obstacle as they move into position, a microswitch is tripped, stopping the lift. You can drive away from the obstacle in the other direction in order to remove the obstacle.

Limit switches

The upper and lower limit switches allow the lift to stop automatically in the correct landing position at the upper or lower end of the staircase. If the upper or lower limit switch fails, the additional final safety limit switch stops the unit.

Emergency stop button

There is a red emergency STOP button located on the platform control panel and on the handheld pendant which can be pressed in an emergency to stop the lift.

Audio visual alarm

The audio visual alarm includes a buzzer and a red running light on the platform control panel that flashes when the unit is in use.

On-board alarm button

The yellow alarm button is located on the platform control panel and can be pressed in an emergency to sound an audible alarm indicating that assistance is required.

Platform key switch

The key switch is located on the platform control panel and is used to activate/de-activate the platform pendant controls.

Overspeed governor (safety brake)

The overspeed governor is a safety device located at the lower end of the rail. It will activate to stop the lift from moving if it is descending down the stairs too quickly.

Manual lowering device

You can use a manual handwheel by inserting it on the motor shaft to bring the lift to the next landing in the event of a power failure.

Site verification

Stairway

Due to close running clearances, the Owner/Agent must ensure that the stairs (where provided) are level, plumb (+/-1/8" (3 mm)) and square and are in accordance with the dimensions specified on the site-specific plan drawings.

Minimum overhead clearance

The Owner/Agent must ensure the minimum overhead clearance is in compliance with codes.

Construction site

The Owner/Agent is responsible for all masonry, carpentry and drywall work as required, and for patching and finishing (including painting) all areas where walls/floors may need to be cut, drilled or altered in any way to permit the proper installation of the lift.

Dimensions

The Contractor/Customer must verify all dimensions on the site-specific plan drawings and report any discrepancies to our office immediately.

Installation

The equipment must be installed by a qualified technician in compliance with the codes identified on the front cover of this manual.

The conformity for access to the platform is the distributor's responsibility.

Electrical requirements

General

Electrical equipment and wiring must comply with Section 38 of CSA C22.1 (Canada) or Section 620 of NEC ANSI/NFPA 70 (USA).

Main power supply

240 VAC single-phase 60 Hz, on a dedicated 15 amp circuit through a fused disconnect. The disconnect should be installed close to the controller, if possible.

Contractor/customer to provide two 14 AWG conductors plus GND conductor between the fused disconnect contact and the power supply box.

Lighting

Lighting must be a minimum of 100 Lux at the platform and landings, and must have a switch and electrical GFCI outlet.

Emergency lighting of 2 Lux must be provided for a minimum of one hour on the platform along the travel route.

Structural requirements

Floor/support wall loads

A structural engineer must ensure that the building and stairway will safely support all loads imposed by the lift equipment. Adequate structural support must be provided at the top landing, bottom landing and throughout the supporting wall along the stairs.

The pull-out force on the supporting wall will vary depending on the type of rail mounting used (wall brackets or support posts). Refer to the rail mounting configurations on the next page. The supporting wall must be able to support the pull-out force as identified in the support load diagram below.

All wood studs in the supporting wall must be anchored in the ceiling and the floor to meet the pull-out force requirements. Wood studs must be placed at 16" (404 mm) centres, solidly anchored in the floor and ceiling.

The floor load will vary depending on the type of rail mounting used (wall brackets or support posts on the steps). The floor must be able to support the loads identified in the support load diagram below.

Where required, the rail must be securely fastened to the structural support wall. Refer to the wall diagram and lag dimensions shown below.

Support load diagram

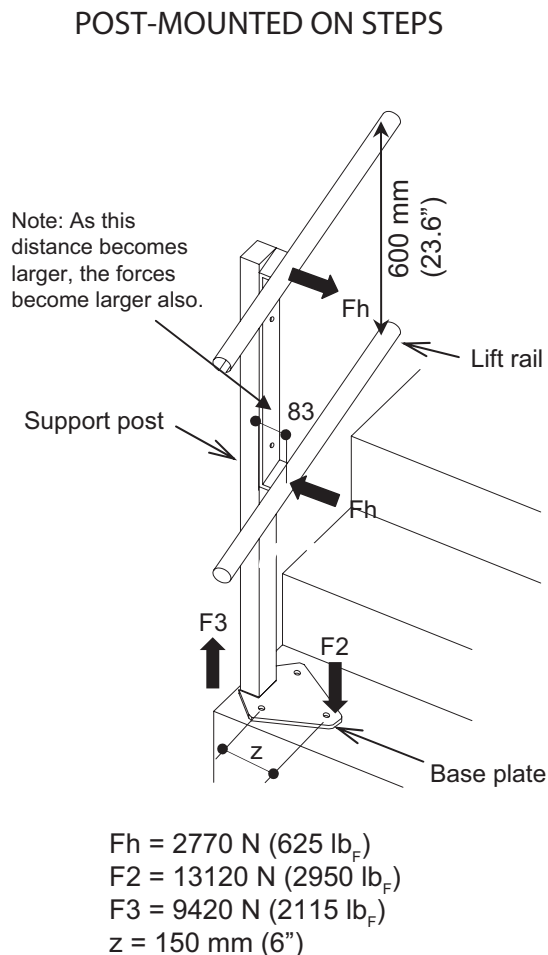
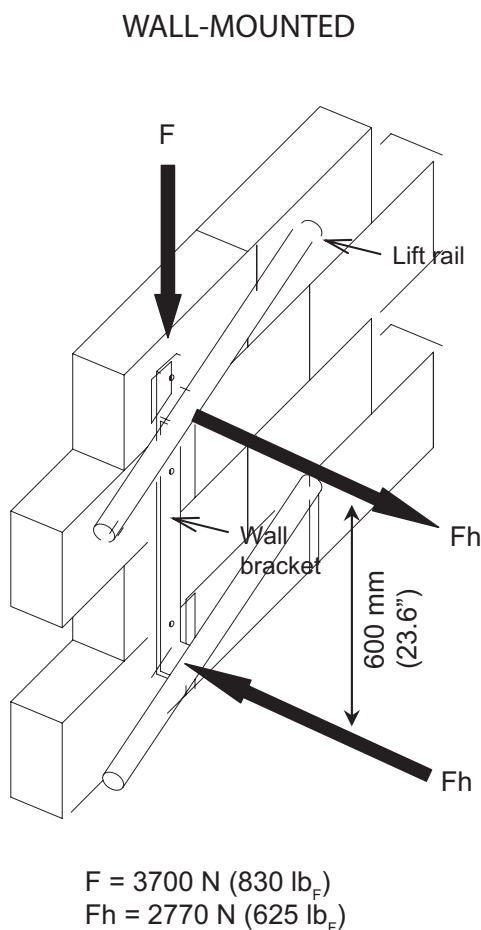

Unfolded platform dimensions

INLINE ACCESS PLATFORM (775 X 1250)

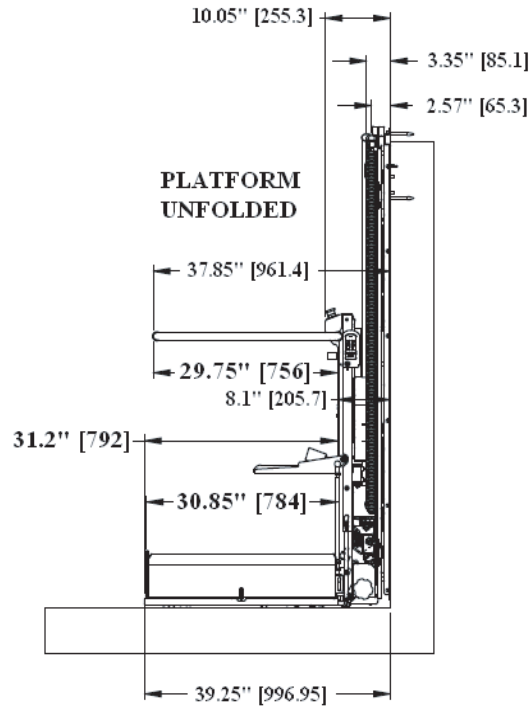

90-DEGREE ACCESS PLATFORM (775 X 1250)

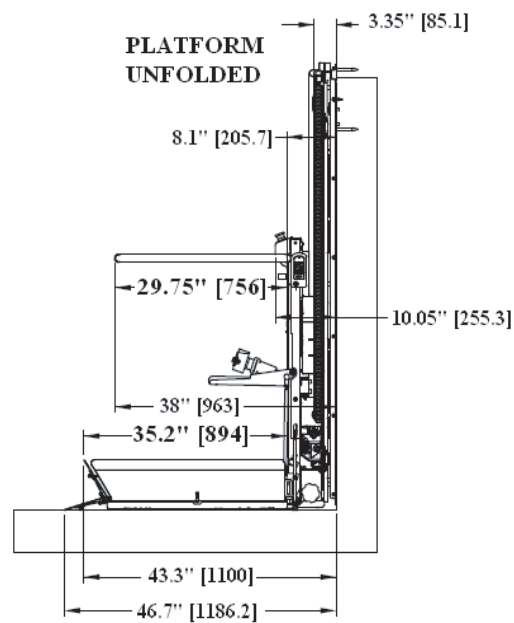

Folded platform dimensions

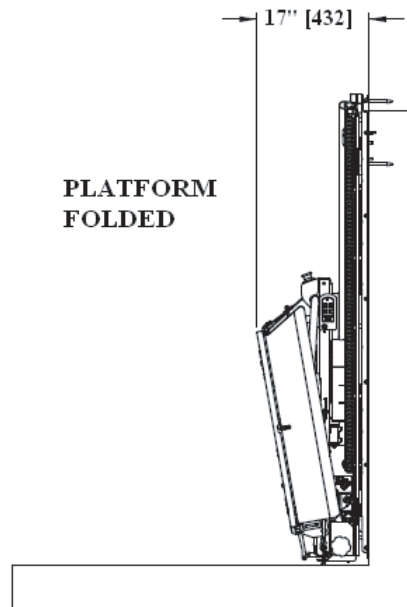

- NOTE:
1. POST ADD 2.5" [63 mm]
 2. 90 DEGREE TURN, ADD 7" (178 MM)
 3. SIDE RAMP ADD 8" [203 mm]

Lower level clearances

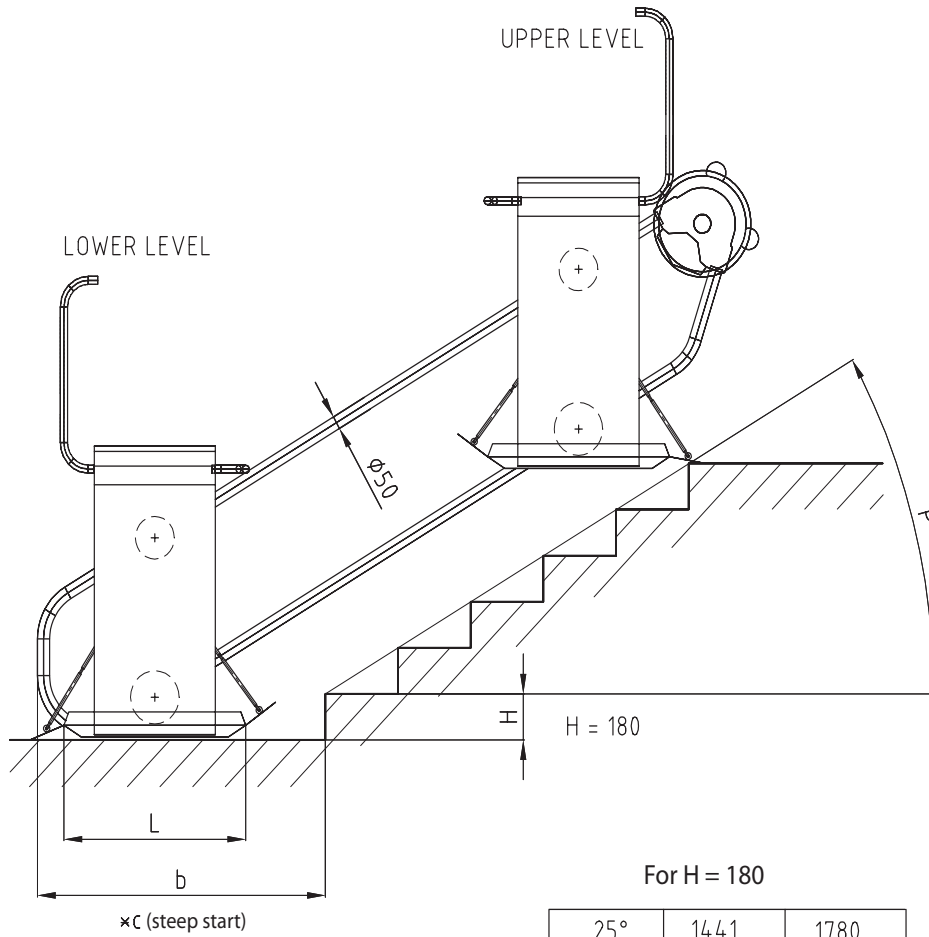

For H = 180

25°	1441	1780
30°	1379	1719
35°	1340	1676
37°	1313	1661
40°	-	-
45°	-	-
47°	1258	1604
P	b	b
RAIL ANGLE	L = 900	L = 1250

STEEP START

150	1231	1576
160	1240	1585
170	1249	1595
180	1258	1602
190	1267	1611
200	1276	1621
H STEP HEIGHT	*c L = 900	*c L = 1250

STEEP START

When there is limited space at the bottom landing, the lower tube section is angled downward at a 45-degree angle so the platform will land as close as possible to the bottom step.

Turning clearances (90 degree curve)

90° CURVE

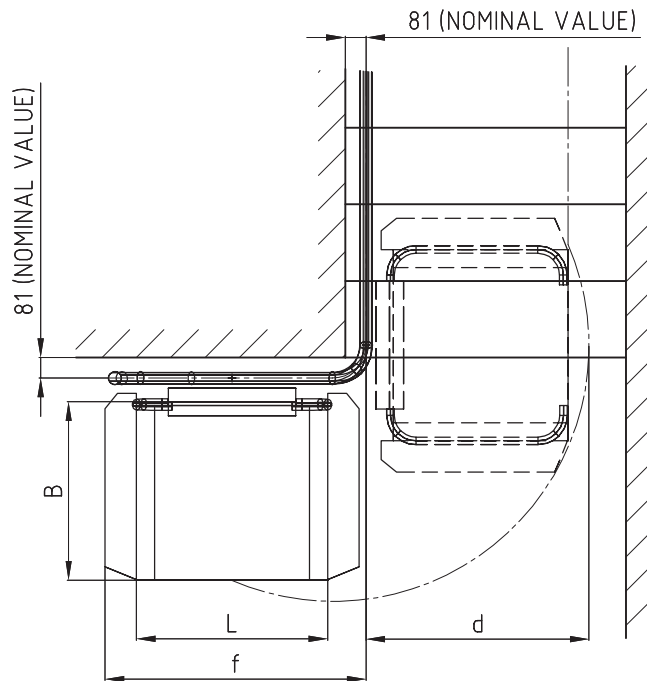
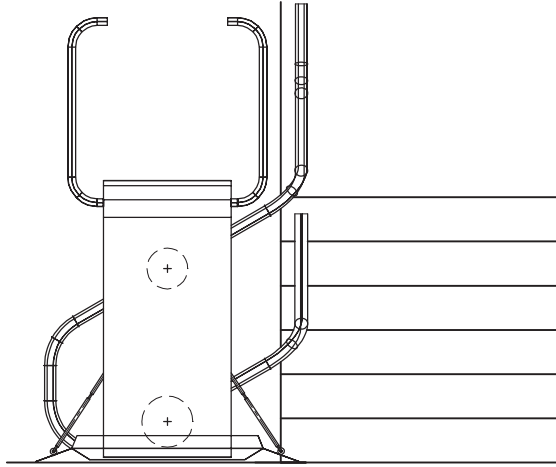

PLATFORM LENGTH L	ACCESS RAMPS	PLATFORM WIDTH B		*f
		720	775	
900	200	931	978	1300
1250	200	1027	1073	1650

Turning clearances (180 degree curve)

180° CURVE

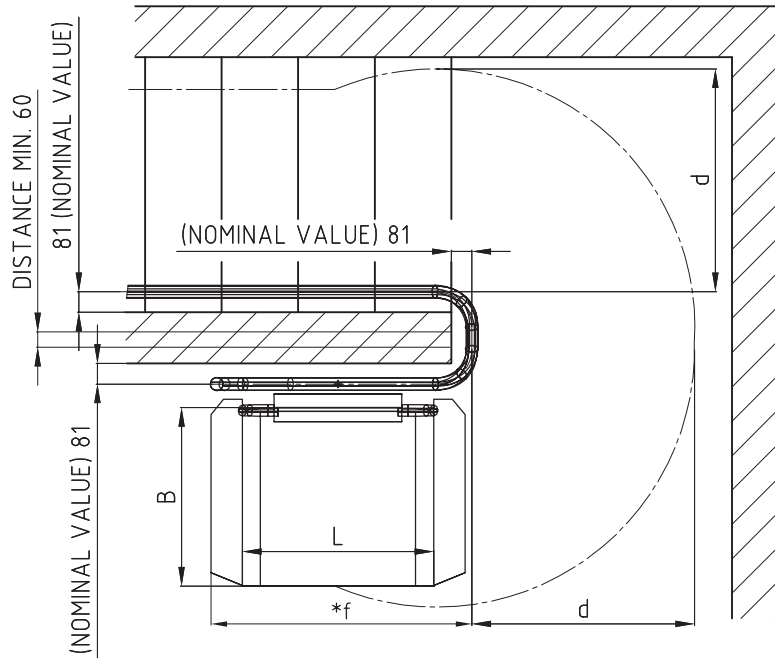
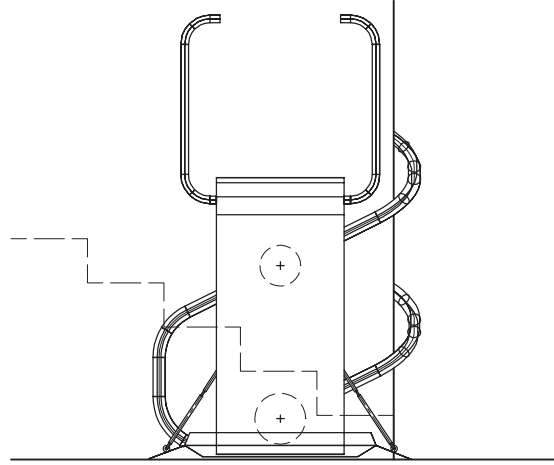

PLATFORM LENGTH L	ACCESS RAMPS	PLATFORM WIDTH B		*f
		720	775	
900	200	931	978	1300
1250	200	1027	1073	1650

Standard drive unit clearances

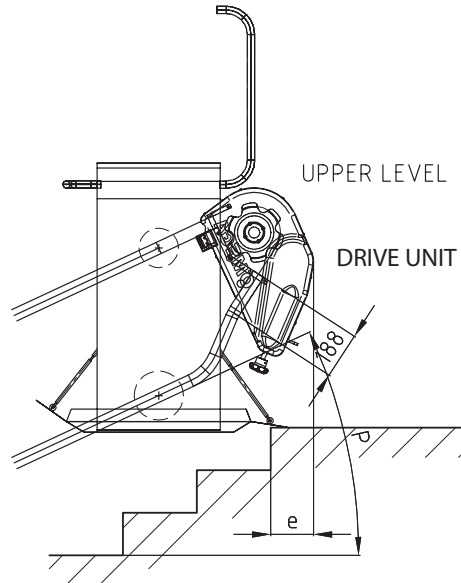

DRIVE UNIT

23°	85	-75
25°	85	-75
27°	85	-75
P	e	e
RAIL ANGLE	L = 900	L = 1250

For reference only; dimensions may vary.

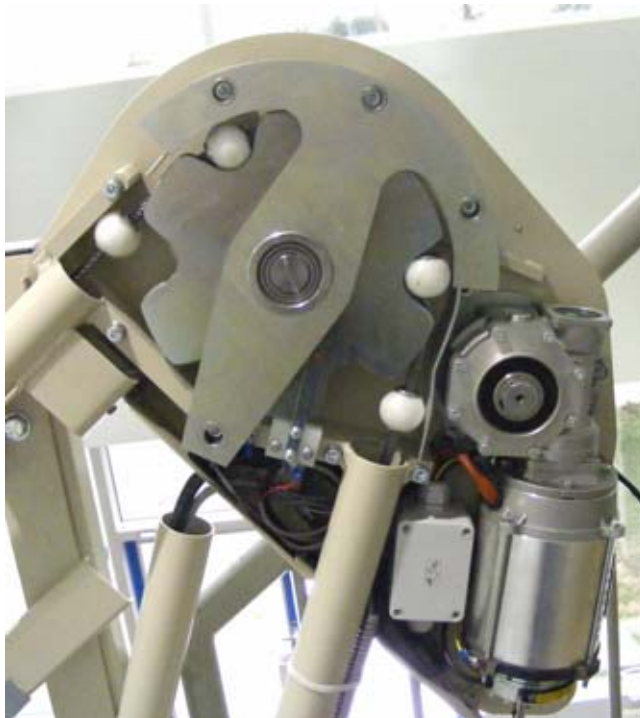

Remote controller box dimensions

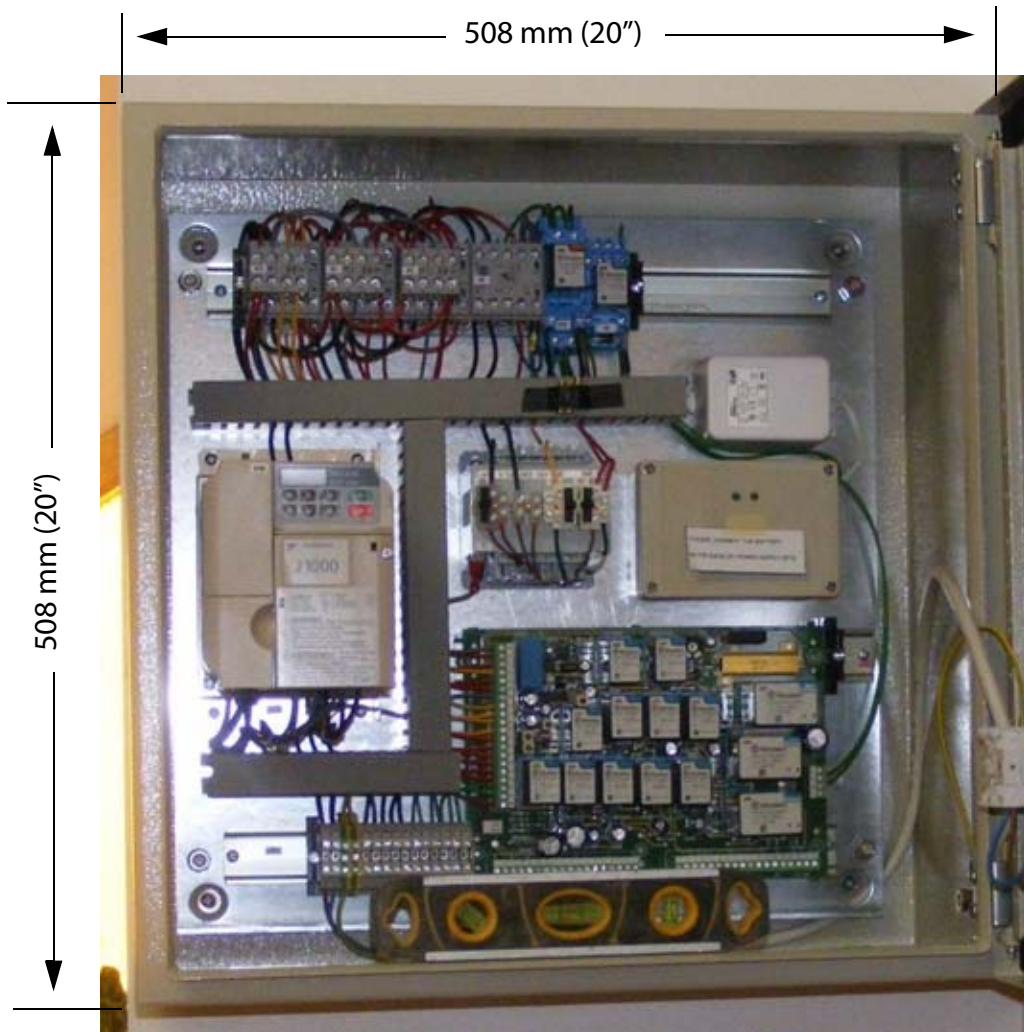

For reference only; dimensions may vary.

Optional large drive/controller cabinet dimensions (sheet 1)

A31150-000-01
MOTOR: 0,75kW

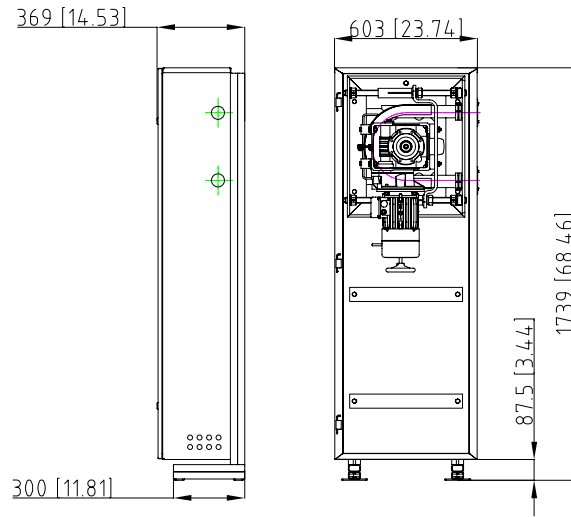

A32240-000-01
MOTOR: 1,1kW

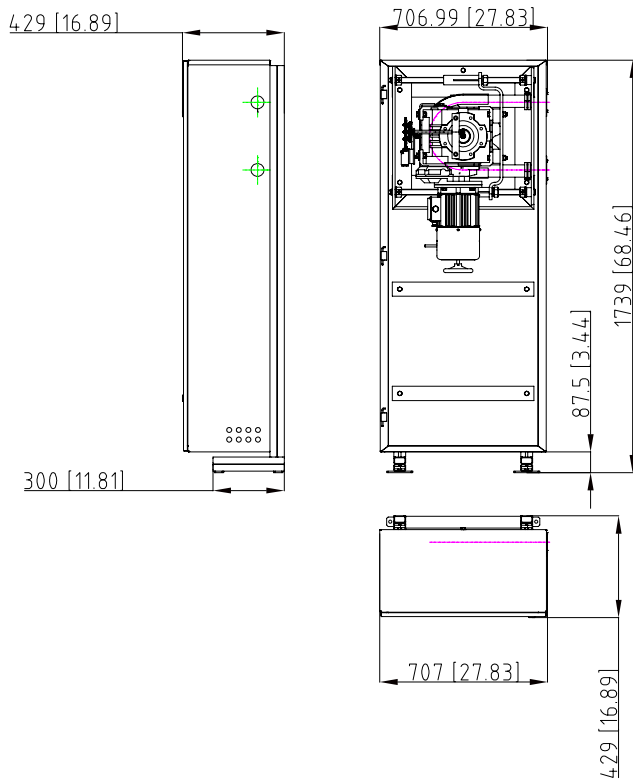

A32120-000-01
MOTOR: 1,1kW

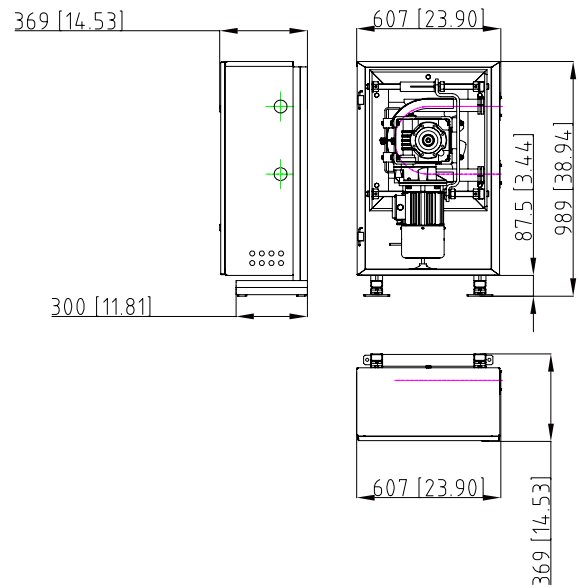

Optional large drive/controller cabinet dimensions (sheet 2)

A34240-000-01
 MOTOR: 1,5kW

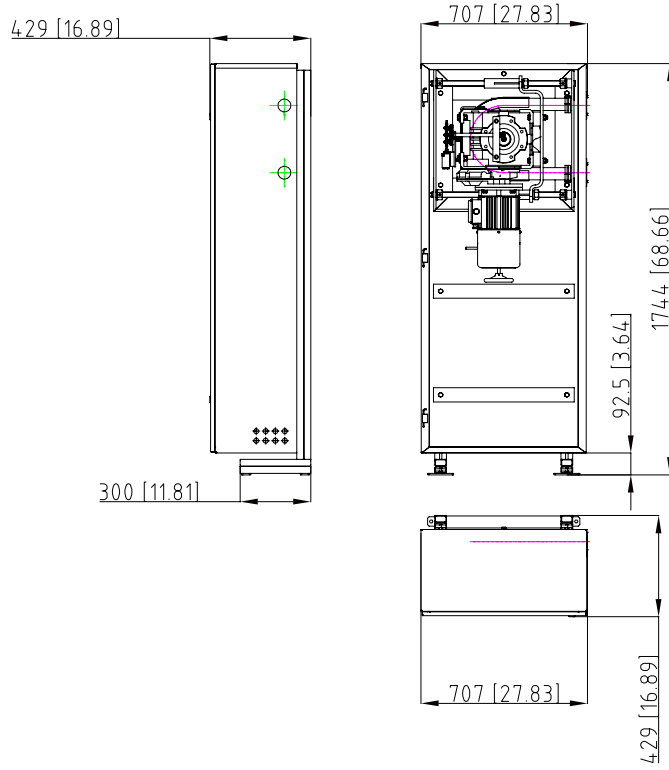

A35240-000-01
 MOTOR: 2,2kW

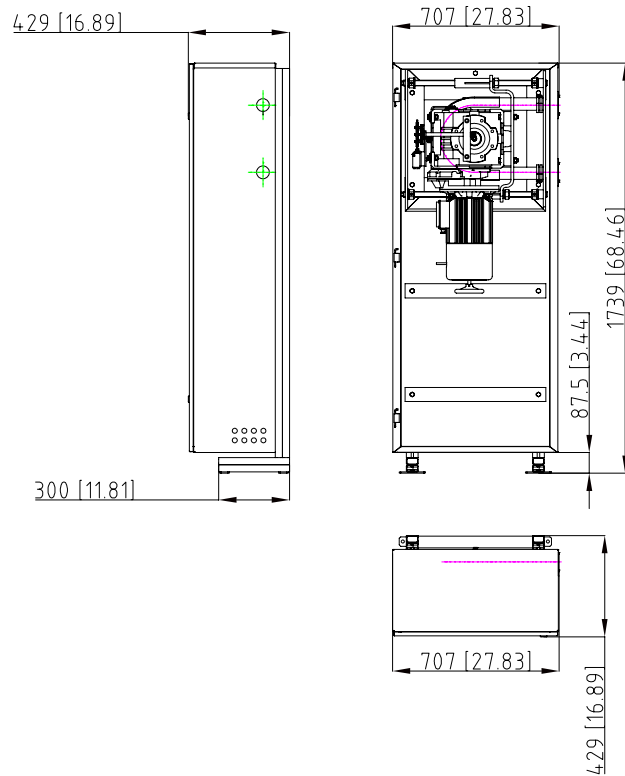

Call station dimensions

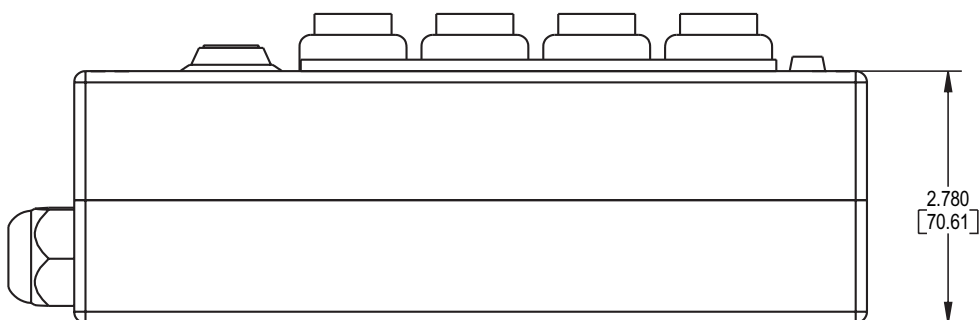
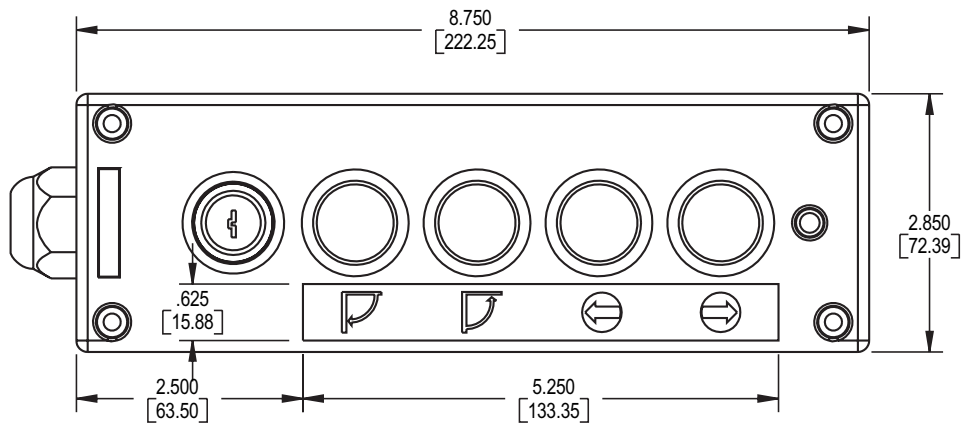
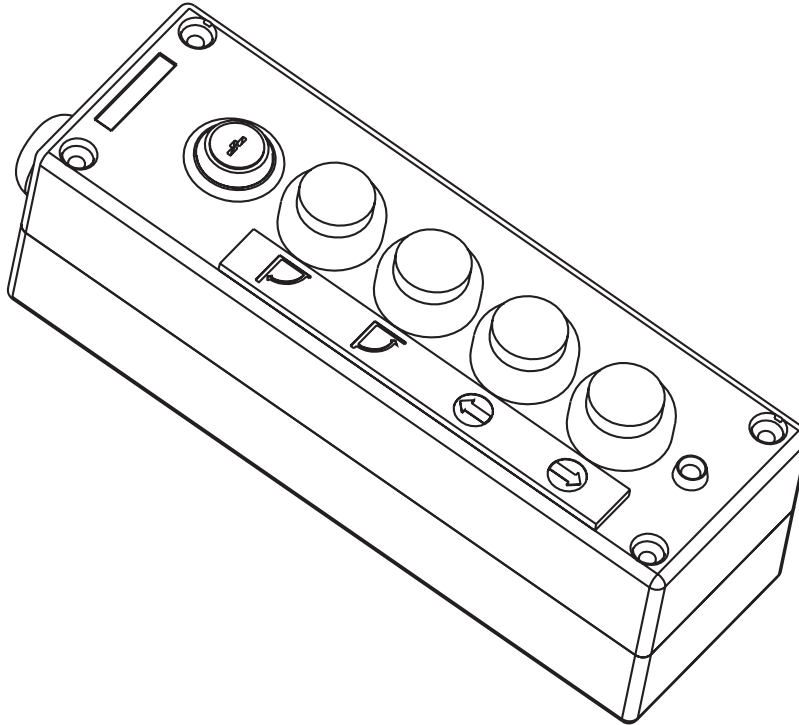

Sample installation wiring layout

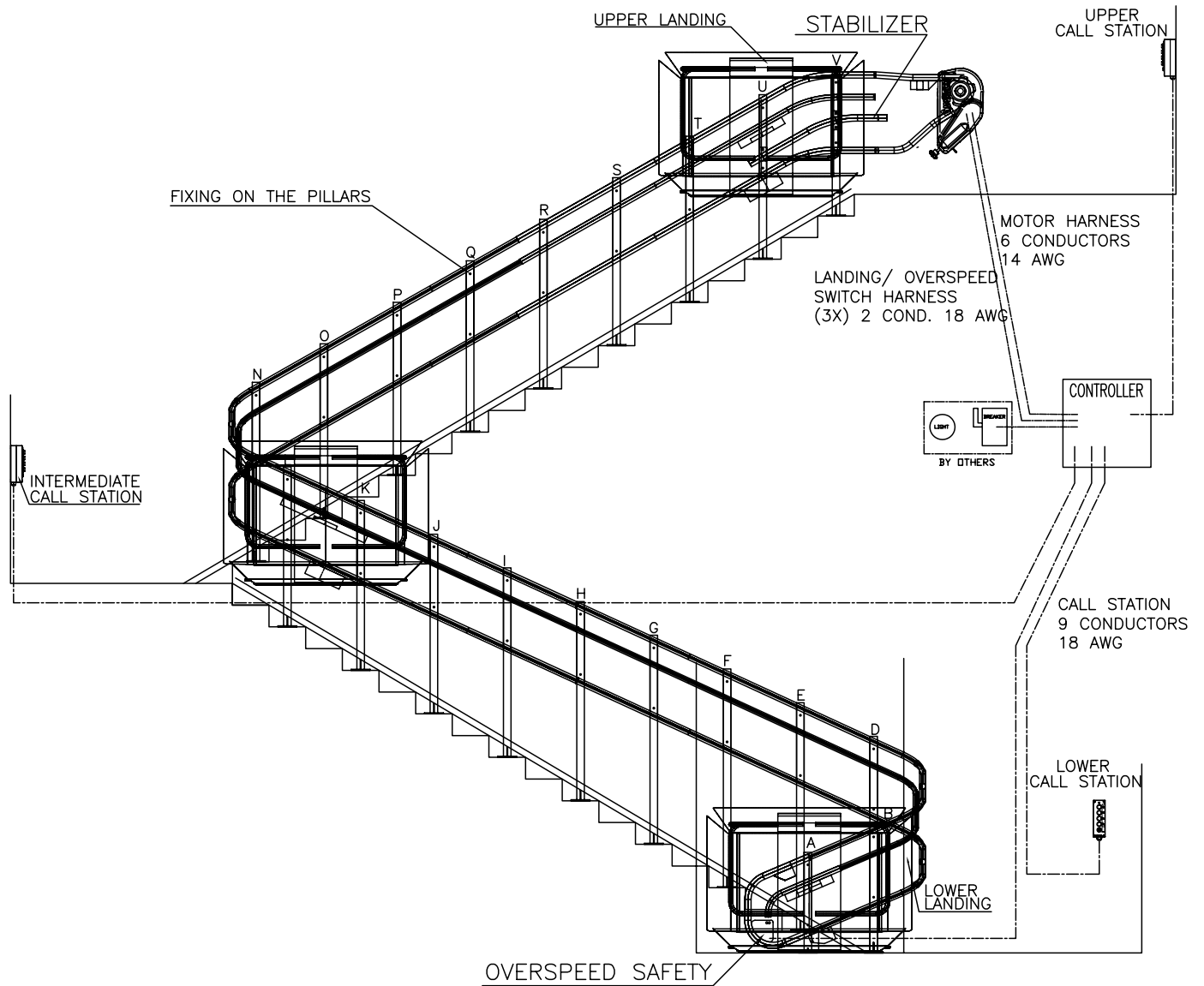

OMEGA

Curved Inclined Platform Lift

PLANNING GUIDE

Part No. 000822
Copyright © 2012

Savaria Corporation
Lifts and Elevators
www.savaria.com

Sales
107 Alfred Kuhne Blvd.
Brampton, Ontario, L6T 4K3, Canada
Tel: (905) 791-5555
Fax: (905) 791-2222
Toll Free: 1-800-661-5112

